



THE AUTOMATIC CHOICE

Innovative solutions
for automatic doors

UK Headquarters

GEZE UK Ltd. Blenheim Way, Fradley Park, Lichfield, Staffordshire WS13 8SY

Tel: +44 (0) 1543 443000 **Fax:** +44 (0) 1543 443001

Email: info.uk@geze.com **Web:** www.geze.co.uk



Dedicated to providing the ultimate in door and window technology

GEZE is at the forefront of cutting edge technology, working in close co-operation with architects of international repute. GEZE add elegance to superb functionality; combine architectural style with efficiency and reliability. Constantly seeking to refine and improve, to break new ground and to offer customers only the very best products and service - this is the philosophy behind GEZE - a team dedicated to providing the ultimate in door and window technology.

Based in Lichfield Staffordshire, GEZE UK, a subsidiary of the German company GEZE GmbH, is a self-sufficient business offering a complete range of products and services. We have made a long term investment in staff skills and have considerable expertise in the automatic door industry.

GEZE UK offers full technical support and advice for supply only and supply and installation customers throughout the planning and installation process and a full range of after sales support including fast reactive responses to emergency door repairs and planned service packages to suit customer and legal requirements.

GEZE technology meets the highest standards of function and design. The flexibility of all the systems allows for individual solutions which incorporate building management requirements. Each year, GEZE invests millions of Euros in research, development and new technology, making them pioneers in door and window control systems. GEZE holds the sought after certification, ISO 9001 which marks out the company's quality assurance and quality management, as well as ISO 14001 for effective environmental management. Over 150 years of engineering and experience goes in to our door and window systems.

GEZE UK offers German engineering with UK expertise and service for all building access solutions.

- Automatic doors 4
- Types of doors 6
- Why GEZE? 8
- Sliding doors 10
- Curved sliding doors 18
- Swing doors 22
- Folding doors 32
- Revolving doors 34
- Product data 36
- Support products 38
- Quickcare 40
- Repair and maintenance 42
- Your issues are our issues 44
- Accreditations 46



Automatic doors

Intelligent automatic entrance systems provide a safe, efficient and convenient means of access and egress to a building.

Automatic door systems are perfect for busy entrances from an office complex to retail centres, from sports stadia to hospitals, from hotels to airports, from government buildings to schools and colleges, the front entrance is the welcoming face of the building that sets the tone of what to expect inside.

Our automatic doors are also regularly used throughout a building; swing doors are perfect for corridors or offices, folding doors are perfect where space is limited and bi-part sliding doors are frequently used in lobbies.

GEZE automatic door entrances are supported by a wide range of safety systems and activation devices from a simple push switch to a sophisticated building management system. Each system is tailored to the customer's requirements to ensure it meets the needs of the building and those using it.

Automatic entrance systems are not only attractive but functional as well:

- Maintaining an even temperature
- Providing access for all
- Enabling compliance with the Equality Act
- Offering security

The introduction of the Disability Discrimination Act of 1995 and the subsequent Equality Act 2010, along with BS 8300 and Approved Document M of the Building Regulations is welcomed.

Anything designed to improve accessibility for all can only be good but it does present contractors and specifiers with additional demands to consider when designing a building.

Sustainability is a major concern in modern construction and GEZE automatic products help save energy by ensuring that doors are shut efficiently, safely and securely. This is part of the reason why our tried and tested systems are frequently specified for lobbies, entrances and doorways of temperature controlled environments.

Whatever the demands of your project GEZE UK can help with a range of automatic operators, advice and support to provide a customer specific solution.

Machinery Directive 2006/42/EC

The Machinery Directive is an Act and therefore a legal requirement. It states that if your product is a machine then it falls under this directive which outlines the legal requirements and obligations for safeguarding users; it defines only the essential health and safety requirements. It states products have to conform and be fit for purpose and safe to use. An automatic door is a machine and so must conform with the Directive.

The European standard EN 16005 is the code of practice for safety in the use of automatic doors for pedestrian use, and is derived from The Machinery Directive.





Sliding doors

Sleek, elegant, space-saving sliding doors are the choice for a modern, contemporary look for today's technology driven buildings. Perfect for coping with heavy traffic areas and providing flexibility through sliding, telescopic or circular systems, automatic sliding doors are the ideal solution to the demands of many building types.

GEZE offer a range of automatic sliding door systems suitable for all applications from a single leaf sliding door fixed to a metal frame to the Slimdrive SL NT that can be bolted to an all-glass façade. A sliding telescopic version is also available that enables designers to create an entrance that provides the maximum opening.

Swing doors

Swing doors are the choice when an easy to use entrance is required or there is a restricted opening. Easily installed, swing doors can be used throughout a building with the added advantage that they can easily be retro-fitted when required.

Swing doors can also be used to provide an alternative access point to complement a more prestigious entrance such as a revolving automatic door system to comply with the requirements of the Equality Act.

Revolving doors

When a strong focal point is required, few types of automatic doors are as attractive and eye-catching as an automatic revolving door especially when the all-glass option is chosen.

Stylish and smart automatic revolving doors complement almost any building but with the current demand for glass façades, revolving doors add that something extra. Revolving doors are not only beautiful but functional as they provide an energy efficient entrance that limits heat loss.

Folding doors

Sometimes the choice of an automatic door is dictated by the space available in an existing building. This is where automatic folding doors come into their own as they are perfect for retro-fitting and can be installed into very small entrance spaces.

As folding doors operate in a very limited space they enable automatic doors to be installed where other types may not be an option.





Why GEZE?

Supply and installation service

GEZE offer a complete supply and installation service. From technical advice and design support through to installation, we provide a customer specific package solution.

Our project managers are your personal point of contact offering you advice at every stage of the project and coordinating with our planners, engineers and manufacturing teams to ensure your entrance is installed smoothly and efficiently.

Strategically located around the country they carry out detailed site visits ensuring the suitability of the selected entrance for the building, decide the most suitable activation and safety systems, carry out a risk assessment, and obtain the measurements... in fact every detail needed for the project. Not only do they

manage the project but they will keep you informed every step of the way.

Our project managers are fully supported by an extensive internal team who translate all the information obtained into the details needed to manufacture and install the automatic door.

GEZE UK is leading the way with some of the best-trained and most highly qualified engineers in the industry. A huge investment has been made to ensure all engineers are fully equipped with all the skills they need, and have already gained or are working towards the nationally recognised NVQ.

GEZE UK project managers and engineers are fully trained to EN 16005 and CITB. The CITB health and safety test leads to the registration of the NVQ Specialist Door Installer. In addition they are ADSA qualified and hold the CSCS qualification.

The Slimdrive Range

GEZE is the first manufacturer to offer a complete series of automatic doors with an automatic drive of just 7cm in height.

The extremely slim design makes it possible for contractors and specifiers to locate the drives so that they are nearly invisible in elevation. The range can be integrated elegantly into any façade or structure and is suitable for use in all public buildings.

This series of drives distinguishes GEZE as a one point of call for all fitting requirements, offering the designer the largest possible design freedom as well as individual design solutions.

The Slimdrive range is available in swing, sliding, including telescopic and curved, and folding options.





Slimdrive SL NT

Just 7cm

Features

- The most compact sliding operator available
- Operator height is just 7cm
- Overall depth is 193mm
- Suitable for doors up to 125kg per leaf
- Can be easily integrated into almost any façade
- Especially suited to glass façades
- Suitable for retro-fitting
- Environmentally friendly due to economical use of materials and energy
- Low wear and maintenance free high performance DC motor
- Virtually silent operation
- Enables compliance to the Equality Act and BS 8300

Applications

- The Slimdrive SL NT is extremely versatile and can be used for a wide range of applications: retail stores and shopping centres, hospitals, offices, transport interchanges
- It is suitable for single or double leafed doors consisting of aluminium frames, ESG toughened safety glass with slim profile frame, 22mm double glazed glass or frameless door leaves with concealed fittings (IGG)
- The Slimdrive SL NT is suitable for use on both internal and external doors
- Ideal for creating wide, impressive entrances



Part of the Slimdrive range the Slimdrive SL NT is an automatic sliding door system that offers flexibility, reliability, functionality, efficiency and safety.



The extremely slim design of the Slimdrive SL NT makes it possible for the operator to be concealed in any façade giving designers the freedom to design stylish entrances.

volume of traffic and where opening and closing a door manually is just not appropriate.

The Slimdrive SL NT is an intelligent automatic door system perfect for busy entrances to buildings such as shopping centres, hospitals, stores, anywhere where there is a high

The Slimdrive SL NT offers a variety of applications from the simplest, almost mundane application to the grandest all-glass façade. Two or more Slimdrive SL NTs can be combined to provide a draught-proof lobby.

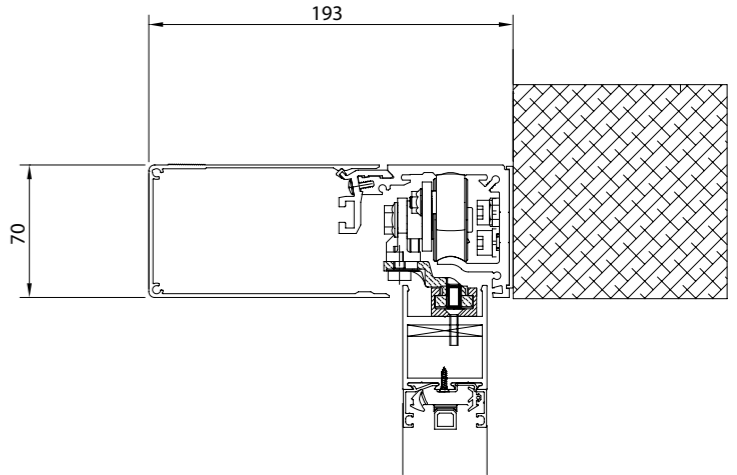
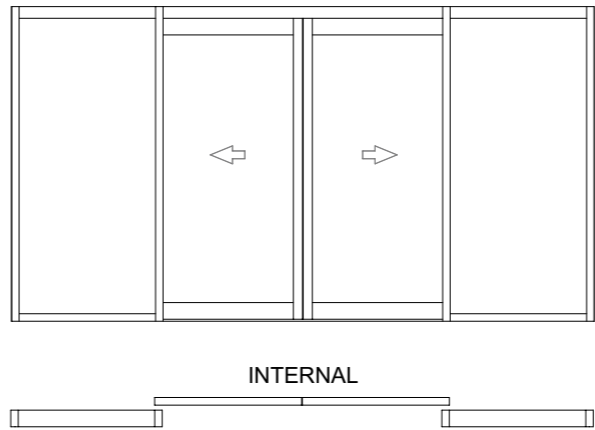



Slimdrive SLT

Just 7cm



Features

- The most compact telescopic door operator available
- Operator height is just 7cm
- Makes opening widths of up to 3600mm possible
- Suitable for doors up to 80kg for both 2 and 4 leaf
- Easily integrated into almost any façade
- Suitable for retro-fitting
- Environmentally friendly due to economical use of materials and energy
- Enables compliance to the Equality Act and BS 8300

Applications

- The Slimdrive SLT system is used for two or four-leaf telescopic sliding doors made of 10mm and 22mm isolating glass or frameless leaves (GEZE IGG) with concealed fittings
- Suitable for internal and external use
- Can be used to achieve very large opening widths
- Ideal for high traffic areas

Another addition to the Slimdrive range is the SLT, telescopic sliding door system.

As with all automatic operators in the Slimdrive range the Slimdrive SLT has an extremely slim profile, just 7cm, making it possible for the operator to be concealed in any facade providing designers with the freedom to design.

The extremely powerful, yet quiet, Slimdrive SLT is used for two or four-leaf telescopic doors.

This space-saving door system is perfect for when space is at a premium as it provides the maximum amount of clear space possible and as the Slimdrive SLT opens and closes quickly it is ideal for high traffic areas such as shopping centres and train stations.

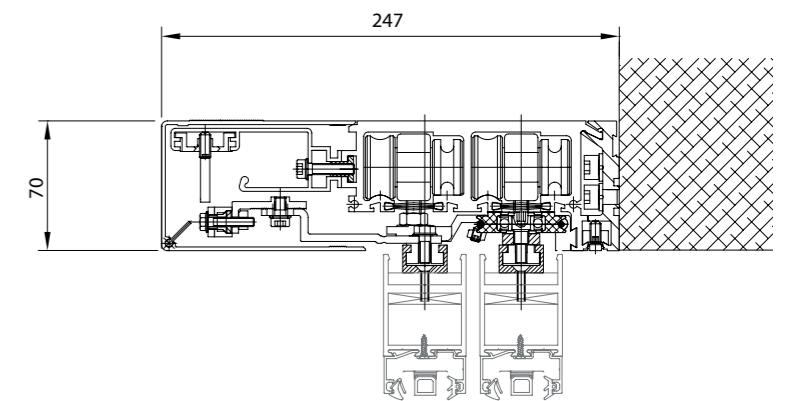
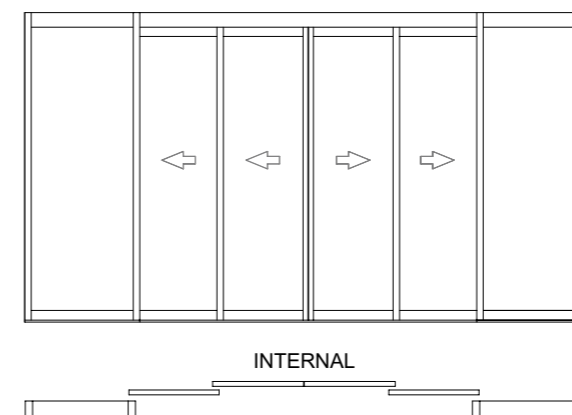



Features

- Designed especially for use with heavy doors
- Powerful drive
- Suitable for door widths up to 3000mm
- Leaf weight up to 200kg
- State-of-the-art DCU control technology
- Self cleaning roller carriages ensure long service life and reduced noise
- Easy adjustment of the sliding door leaf
- Electro-mechanical locking system
- Enables compliance to the Equality Act and BS 8300

Applications

- The Powerdrive is designed for situations that demand heavy doors and large entrances
- Suitable for internal and external doors
- Suitable for single and double leaf doors
- For use with toughened safety glass, insulation glass, framed and timber doors

Powerdrive

The Powerdrive PL is the powerhouse for big, heavy door leaves and large opening widths.

The economical yet high-capacity Powerdrive can move door leaves of up to 200kg in weight making it ideal for those situations that demand heavier doors and large entrances. Convenience and safety for heavy doors are the trademarks of the Powerdrive operator.

Functionality is paramount; integrated brushes continually clean the rollers ensuring long-lasting quiet operation and low wear whilst the use of state-of-the-art control technology makes it easy to use, provides excellent safety and allows connection to

a variety of control devices. Large entrances and opening widths or heavy door leaves make substantial demands on door drive technology, and this is precisely what the Powerdrive has been designed for.

Ideal for use in areas where there is a demand for large automatic doors such as hospitals and airports. The Powerdrive HT is a hermetic sliding door system specifically designed for use in areas where hygiene and cleanliness are essential.

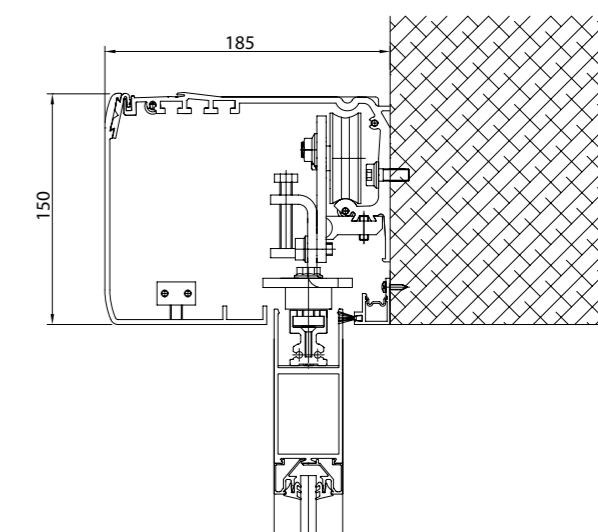
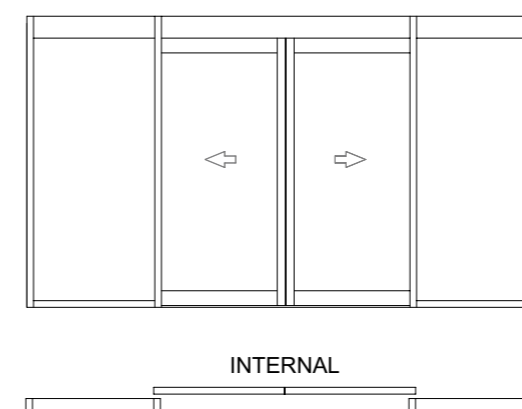



ECdrive



Features

- Simple assembly and adjustment
- User friendly
- Suitable for door widths up to 3000mm
- For doors up to 120kg
- Fulfills highest safety requirements
- Reliable operation
- Self-cleaning roller carriages ensure long service life and reduced noise
- Enables compliance to the Equality Act and BS 8300

Applications

- Suitable for single and double-leaf doors
- For use with toughened safety glass, insulation glass, framed and timber doors
- For internal and external doors
- Suitable for high usage areas

The ECdrive is an attractive and reliable automatic sliding door operator providing functionality and economic efficiency.

Designed for high usage areas the ECdrive combines the high quality and advanced electronics GEZE are known for with reliability and safety, yet delivers an excellent cost/benefit ratio.

Suitable for all types of applications, the system is extremely quiet due to the low abrasion and self-cleaning roller system.



The ECdrive safely and easily moves doors up to 120kg and the system incorporates proven GEZE DCU technology and accommodates the latest activation equipment.

Economical and convenient the ECdrive enables compliance with current laws and regulations.

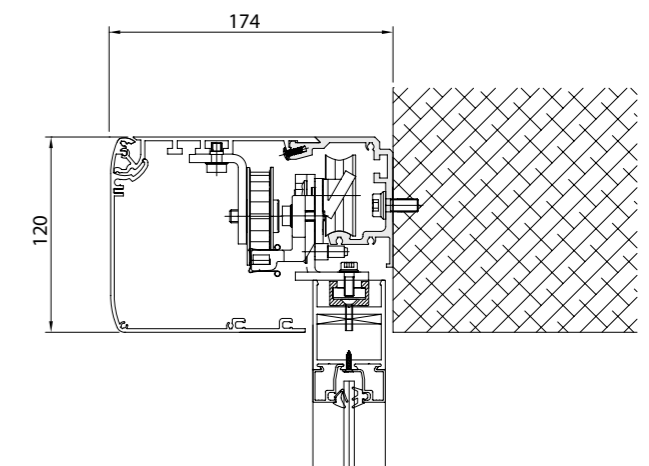
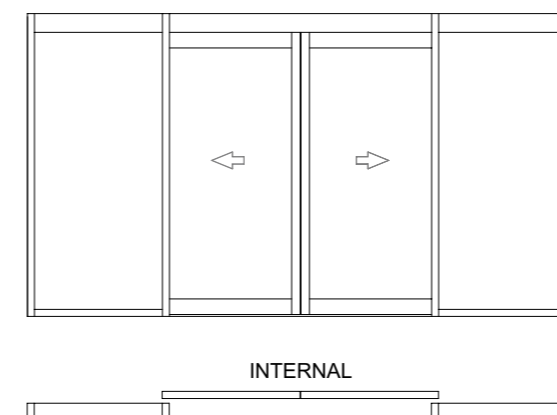



Features

- The most compact semi-circular curved sliding operator available
- Opening width double leaf: 2000mm
- Weight of double leaf: max. 2x 100kg
- Extruded cover profiles in a full range of RAL colours, EV1 and stainless steel
- Door carriages with double rollers ensure extremely quiet running and optimum weight distribution
- Fully modular construction consisting of mounting profile, track profile, cover, side parts and clamping profiles
- Maintenance free, fully enclosed, quiet running DC motor
- Mains connection: 230V +6%/-10%, 50/60Hz
- Power consumption: max. 300 VA
- Enables compliance to the Equality Act and BS 8300

Applications

- Suitable for entrances where space may be limited
- Can be combined with other types of automatic doors to create a lobby

Offering more light and space the Slimdrive SC provides an attractive, spacious entrance to any building.



As part of the Slimdrive range the automatic operator is just 7cm high enabling the drive to be mounted almost invisibly giving architects and designers more freedom to design. Available as a semi-circle or as a sleek and elongated radius the Slimdrive SC operator enhances any entrance.

The slim profile system surrounds laminated safety glass which contributes to the elegant impression and provides

a larger clearance. The entrance is enlarged by up to 40% in comparison with linear sliding doors.

Flexible and versatile the Slimdrive SC can be installed nearly everywhere - concrete, masonry, steel or glass façades and is suitable for use in any type of building including areas where space is limited. The Slimdrive SC fulfils the highest demands of function and design.

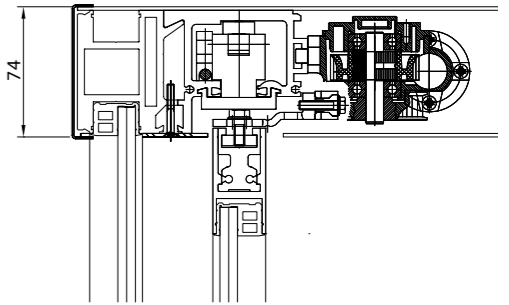
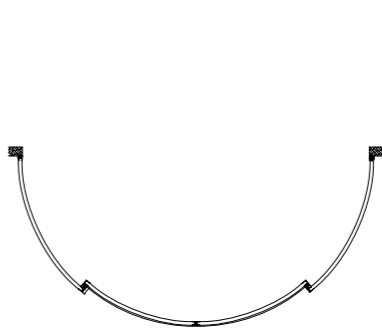
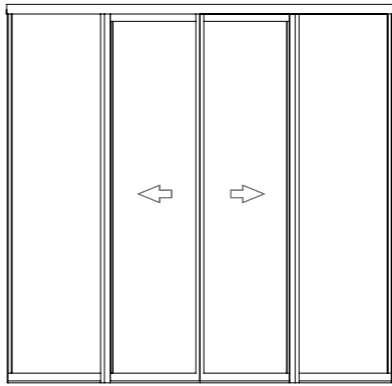



Slimdrive SCR

Just 7cm



Features

- The most compact completely curved sliding operator available
- Maximum opening width 2000mm
- Weight of double leaf: max. 2 x 120kg
- Extruded cover profiles in a full range of RAL colours, EV1 and stainless steel
- Door carriages with double rollers ensure extremely quiet running and optimum weight distribution
- Maintenance free, fully enclosed, quiet running DC motor
- Mains connection: 230V +6%/-10%, 50/60Hz
- Power consumption: max. 300 VA
- Enables compliance to the Equality Act and BS 8300

Applications

- Suitable for wherever a large impressive or unusual entrance is required
- Provides a draught proof lobby

The Slimdrive SCR is a curved sliding automatic door operator that is perfect for creating a draught-proof, light and spacious lobby. It maintains air temperature providing a more comfortable place for staff to work that offers environmental benefits and fuel efficiencies yet creates an impressive, attractive entrance.



As part of the Slimdrive range, the SCR's automatic operator is just 7cm high enabling the drive to be mounted almost invisibly and blend seamlessly into the façade giving architects and designers more freedom to design.

The versatile Slimdrive SCR is suitable for use on all types of buildings and can be mounted on all manner of façades:

concrete, masonry, steel or glass. It is especially suited to areas of high usage such as colleges and offices.

The Slimdrive SCR increases the available space as a circular entrance enlarges the opening area by up to 40% in comparison with linear sliding doors. Combining light and space, outstanding entrances are created with the Slimdrive SCR.

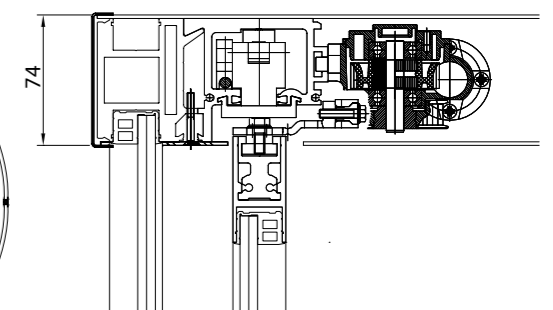
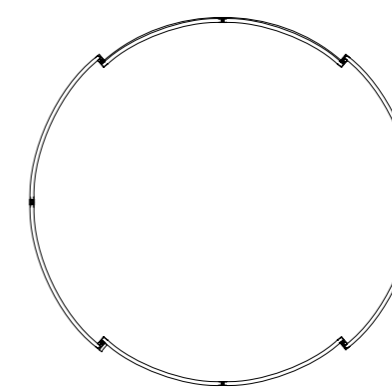
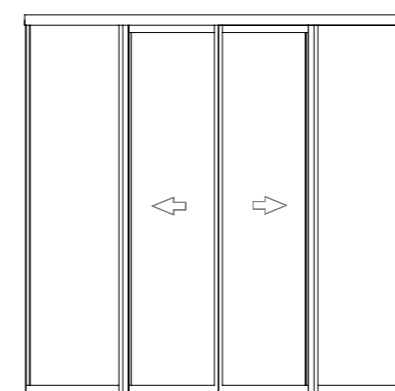



Powerturn



Features

- Flexibility, Powerturn can be integrated into a wide range for systems
- Low overall height of only 7cm
- Maximum leaf weight 600kg or
- Door leaves of up to 1600mm
- Operating modes: automatic, permanently open, night, shop closing
- Push & Go (adjustable) function
- Low energy function
- Can be used manually
- For left and right hand doors
- Enables compliance to the Equality Act and BS 8300
- Reliable opening and closing even under adverse conditions

Applications

- For use on internal and external doors
- Can be door mounted or transom mounted
- Barrier free
- For single and double leaf doors
- For use on escape and rescue routes, and in smoke and heat extraction systems

All subject to application

Perfect for opening large, heavy doors reliably and safely the Powerturn can be integrated flexibly in a wide range of different systems.



Powerturn features GEZE's new Smart swing function – a unique operation of the energy storage system in which the spring that ensures safe closing of the drive in the event of a fire is preloaded and kept in this position. This allows even large and heavy doors to be manually opened by anyone from children to people with restricted mobility with ease.

Powerturn is flexible too, its low overall height, ability to move large and heavy doors, can be used on single or double leaf doors and can be combined with other door control systems – escape and rescue routes, smoke and heat extraction, interlocking door systems – gives the designer freedom to design whilst still meeting all safety and accessibility requirements.

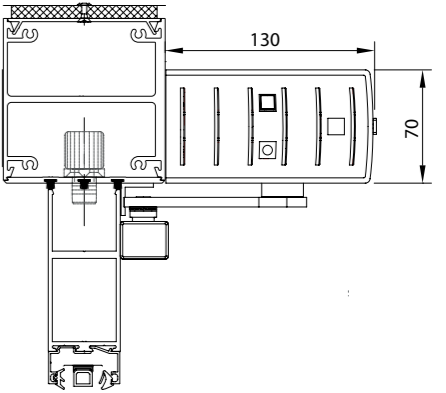
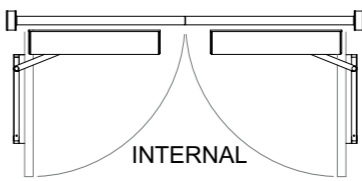
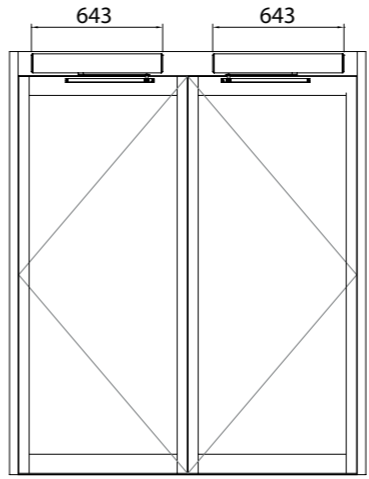



TSA 160 NT



Features

- Exceptional versatility, reliability and functionality
- Suitable for door leaves up to 250kg (subject to site survey)
- Successfully fire tested to EN1634-1 (Fire certified by Warrington)
- Requires very little energy and service
- Compatible with the full range of GEZE activation devices
- Easy to retro-fit into an existing application
- Enables compliance to the Equality Act and BS 8300

Applications

- Available for single or double door versions
- Especially suitable for lobbies, entrances and doorways where temperature controlled environments are required
- Extremely versatile and suitable for a wide range of applications
- Suitable for use on fire doors and emergency exits
- The TSA 160 NT can be retro-fitted and is suitable for use where space is limited
- TSA 160 NT EN7 power size EN7 for door leaves up to 1600mm

An excellent workhorse the TSA 160 NT is suitable for use on internal and external doors and is ideal for areas of heavy usage and particularly suitable for the retail environment.



The new TSA 160 NT builds on the versatility and reliability of the previous TSA 160 but delivers even greater functionality. Additional functions are available through the optional Display Programme Switch (DPS) which provides settings for winter and summer mode, access mode, exit only mode and dynamic hold open time mode.

The TSA 160 NT offers maximum convenience and safety and is ideal for use in a wide range of applications

including hospitals, schools, homes for the elderly or those requiring assistance, as well as airports, railway stations, shops and offices.

The TSA 160 NT ensures doors are shut efficiently, safely and securely providing reliable, trouble free operation thereby ensuring entrances are accessible to all. The TSA 160 NT offers the perfect solution.

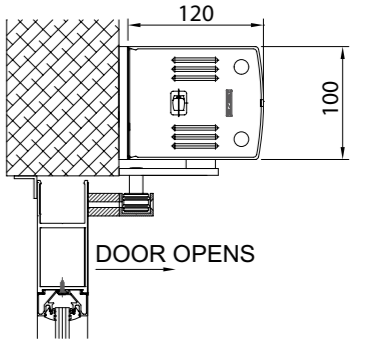
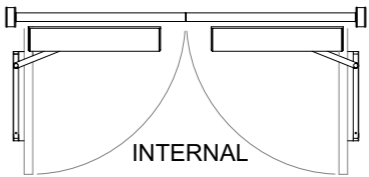
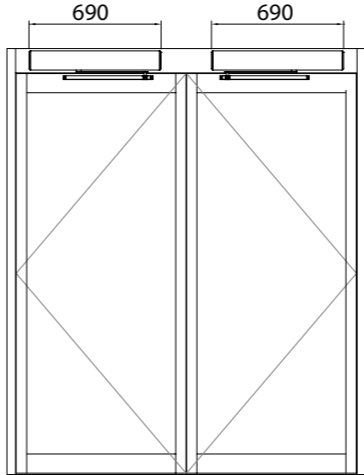



Features

- The TSA 160 UFO operator is fully concealed under the floor
- Suitable for door leaves up to 120kg (subject to site survey)
- Extremely reliable electro-hydraulic operator
- Full adjustment of opening/closing forces, speeds, backcheck and latching
- Unit encased in fully sealed satin stainless steel enclosure
- Single phase 240V power supply
- Control box can be located remotely or discreetly within a free standing bollard
- Enables compliance to the Equality Act and BS 8300

Applications

- Particularly suited for use in buildings where automatic doors are required with an operator that is not visible
- Can be used with any type of door construction including glass, wood or metal
- Suitable for use where vandalism could be a problem as the operator is fully concealed
- Suitable for retro-fitting to existing buildings
- TSA 160 UFO-G with guide rail offers an under floor automatic operator for use with existing butt hinged doors, each application to be assessed individually

TSA 160 UFO

The TSA 160 UFO automatic under floor operator allows for maximum transparency thus achieving architectural beauty with the highest degree of functionality.



Developed from GEZE's highly respected TSA 160 NT transom mounted unit the electro-hydraulic operator is housed within a sealed stainless steel enclosure mounted below finished floor level; incorporating an advanced direct drive for use with all designs of swing doors.

Visually and acoustically unobtrusive the UFO's technologically advanced motor is much quieter than traditional overhead

operators and offers full adjustment of opening and closing forces, speed and latching.

Compatible with most activation and safety devices and with the capability of integration with access control and building management systems the TSA 160 UFO meets the requirements of most swing door installations.

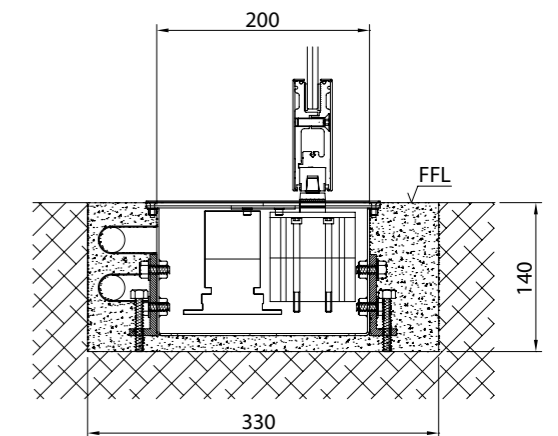
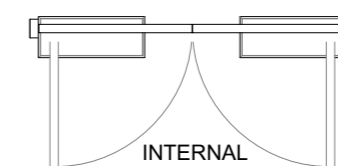
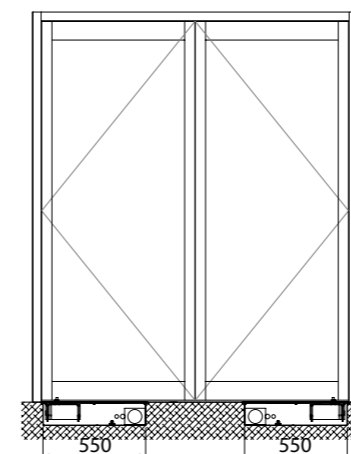



Features

- Compact swing door operator for internal and external doors
- Operator height is just 7cm
- Maximum leaf weight 230kg (subject to site survey)
- Suitable for large and heavy doors
- Suitable for installation on smoke and fire doors
- Low-energy function
- Closing force EN 3-6
- Can be used manually
- Extremely quiet operation
- Enables compliance to the Equality Act and BS 8300

Applications

- Suitable for fire door applications
- Can be door mounted or transom mounted
- Suitable for retro-fitting or in areas with low ceilings or where space is limited

Slimdrive EMD-F

Just 7cm

The Slimdrive EMD-F is an electro-mechanical drive system for swing doors that is particularly suitable for installation on narrow profiles and in situations where space is at a premium.

Part of the Slimdrive 7cm range the Slimdrive EMD-F is a highly compact operator; it will move large and heavy internal and external doors easily and with virtually no noise. The quiet operation is achieved by using a low-noise direct current motor and gears with direct power transmission

to the door leaf with a V arm or guide rail.

Reliable operation of the drive is achieved with a maintenance free high performance motor with low wear characteristics and state-of-the-art control technology.

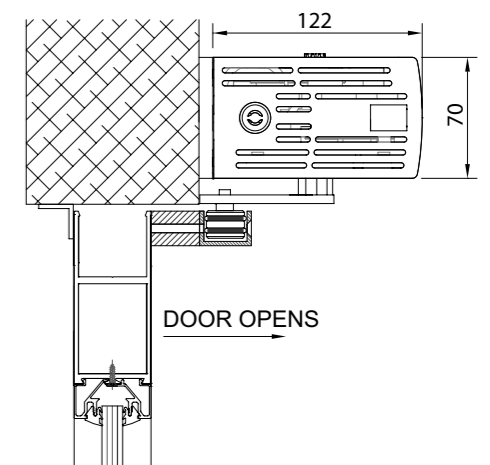
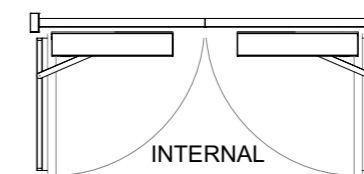
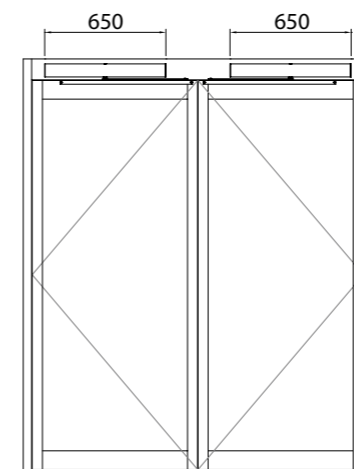



ECturn



Features

- Versatile, compact swing door operator
- Unobtrusive at only 60mm high
- Maximum leaf weight 125kg (subject to site survey)
- Door leaves of up to 1100mm
- 3 operating modes: automatic, permanently open, night
- Push & Go function
- Low energy function
- Can be used manually
- For left and right hand doors
- Enables compliance to the Equality Act and BS 8300

Applications

- For use on internal doors
- Suitable for retro-fitting
- Can be door mounted or transom mounted
- Barrier free internal doors
- Solution for all-glass doors

The ECturn is a highly versatile electro-mechanical swing door drive system for internal doors.

It has been designed primarily for use in sheltered housing, hospitals, schools, residential and care homes, hotel rooms, restaurants and even leisure facilities to provide a quiet, simple accessibility solution and enable barrier free access for all.

The ECturn can be used with a whole variety of control options and in combination with access control and building management systems.



Easy, simple and convenient to use, the doors can be opened manually or automatically with automatic closing and can be operated in low energy mode.

The ECturn Inside enables automatic opening and closing of doors almost invisibly as the drive is integrated into the door leaf or frame and the drive and control unit are not visible when the door is closed.

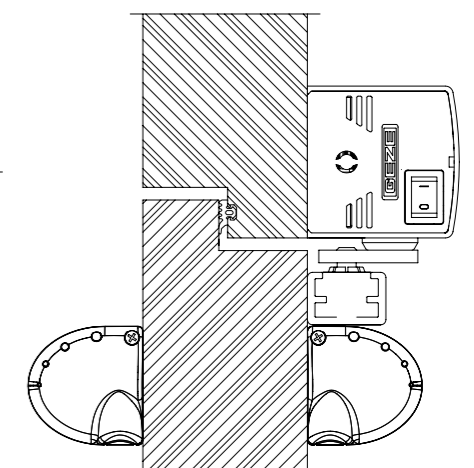
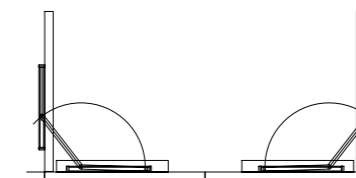
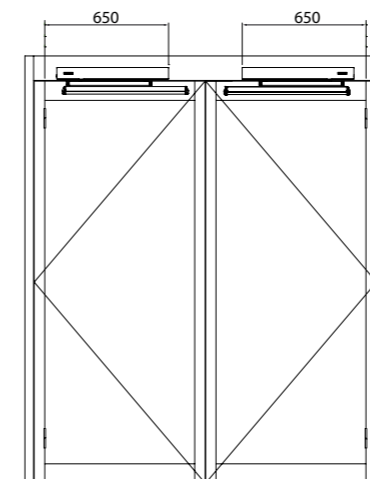



Slimdrive SF

Just 7cm



Features

- The most compact folding door operator available
- Drive unit size only 70mm x 282mm
- Leaf weight 4 x 40kg
- Opening width up to 2000mm (subject to site survey)
- Maximum passage height 2200mm
- Slim profile door system complements design
- Door profiles incorporate finger guards
- Electro-mechanical locking system as standard
- Enables compliance to the Equality Act and BS 8300

Applications

- Perfect for retro-fitting
- Suitable for fitting where ceilings are low or space is limited
- For use where an energy efficient yet effective automatic entrance is required

The Slimdrive SF is a sliding folding automatic door system that offers superb functionality. The extremely slim design enables the drives to be located so that they are virtually invisible offering the designer and architect the largest possible design freedom as well as individual design solutions.

With the ability to operate within limited space the Slimdrive SF enables a large clear opening in the smallest of entrances whilst the high performance motor ensures the Slimdrive SF's doors open smoothly. Perfect for retro-fitting the Slimdrive SF provides barrier free access in even the tightest areas aiding compliance with the Equality Act.

The use of state-of-the-art control technology provides high comfort levels for usage, excellent safety and allows the connection of all control units.

The Slimdrive SF is part of GEZE's range of operators with a height of just 7cm.

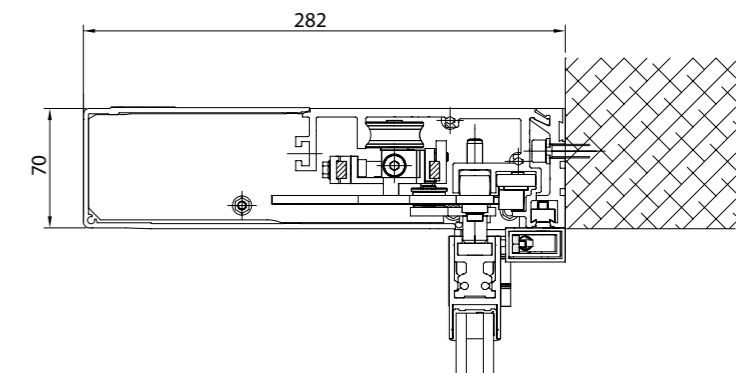
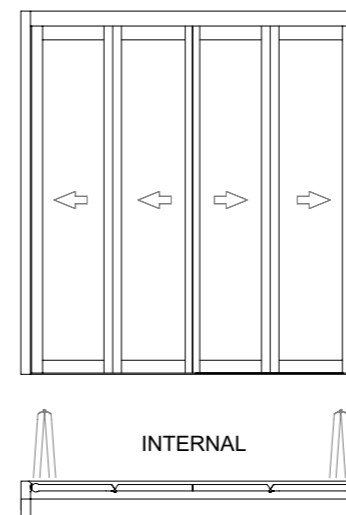



Features

- Attractive and slim aluminium profiles with rounded edges
- From 1800mm to 3600mm any specific diameter may be produced
- Passage heights up to 3000mm possible, larger passage heights on request
- With an automatic drive the canopy height is only 200mm or with underfloor operator 70mm
- Available as an all-glass revolving door system in manual or fully automatic operation

Applications

- Suitable for use in a wide variety of buildings
- Provides a draught-proof and weatherproof entrance
- Suitable for use where access control and security are important
- Provides an energy efficient yet always open entrance

TSA 325 NT

The TSA 325 NT revolving door combines architectural beauty with the highest degree of functionality. Offering an entrance with a diameter from 1800 - 3600mm, the TSA 325 NT is a focal point of any modern façade.



The revolving door has another major advantage; no draught. The high degree of insulation against the elements and noise means that the TSA 325 NT saves energy and ensures a pleasant and consistent climate inside the building.

The TSA 325 NT offers complete flexibility with a variety of revolving doors types to meet different needs. Drive systems are available in fully automatic or manual versions, in a choice

of door leaves (3 or 4), and whether a night sliding door is to be fitted, together with a variety of accessories such as watertight roof cover, fitted halogen lights, etc.

With safety in mind, safety sensors and rubber pressure switches constantly monitor all potential danger points in and around the automatically driven revolving door. The system immediately stops if a pressure switch at the closing edge is actuated.

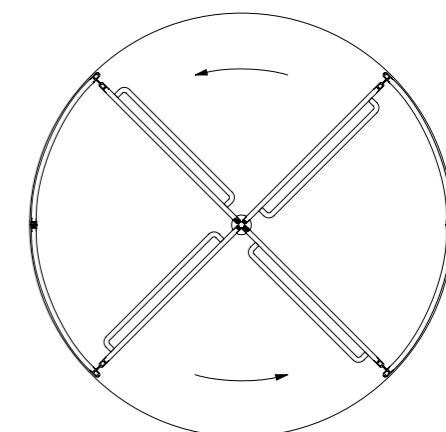
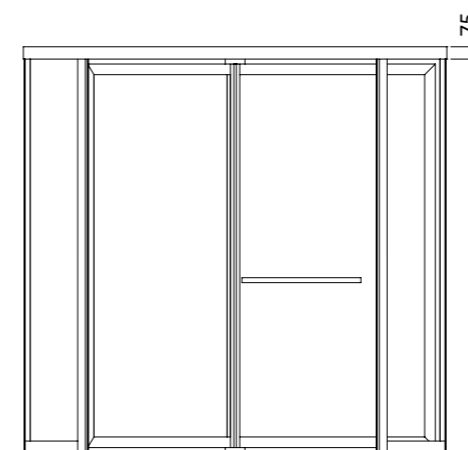



Product data

	Product	Dimensions	Opening width, single leaf	Opening width, double leaf	Opening width, four leaf	Max. leaf weight, single leaf	Max. leaf weight, double leaf	Max. leaf weight, 4 leaves
Automatic Sliding & Telescopic Doors	Slimdrive SL NT	70 x 193mm (h x d)	700 - 2000mm	900 - 3000mm	N/A	125kg	2 x 125kg	N/A
	Slimdrive SLT	70 x 247mm (h x d)	N/A	1000 - 3000mm	2000 - 3600mm	N/A	2 x 80kg	4 x 80kg
	Powerdrive	150 (200) x 185mm (h x d)	700 - 3000mm	800 - 3000mm	N/A	200kg	2 x 200kg	N/A
	ECdrive	120 (150) x 175mm (h x d)	700 - 3000mm	900 - 3000mm	N/A	120kg	2 x 120kg	N/A
Automatic Curved Sliding Doors	Slimdrive SC	1000mm min (rad)	750 - 1500mm	1500 - 3000mm	N/A	100kg	2 x 100kg	N/A
	Slimdrive SCR	1000 - 2000mm (rad)	750 - 1500mm	1500 - 2450mm	N/A	100kg	2 x 100kg	N/A
Automatic Swing Doors	Powerturn	70 x 720 x 130mm (h x l x d)	800 - 1600mm	1600 - 3200mm	N/A	600kg	2 x 600kg	N/A
	TSA 160 NT	100 x 690 x 120mm (h x l x d)	690 - 1400mm	1380 - 2800mm	N/A	250kg	2 x 250kg	N/A
	TSA 160 UFO	200 x 550 x 125mm (h x l x d)	600 - 1400mm	1200 - 2800mm	N/A	120kg	2 x 120kg	N/A
	Slimdrive EMD-F	70 x 650 x 122mm (h x l x d)	750 - 1400mm	1500 - 2800mm	N/A	230kg	2 x 230kg	N/A
	ECturn	60 x 580 x 60mm (h x l x d)	650 - 1100mm	N/A	N/A	125kg	N/A	N/A
Automatic Folding Doors	Slimdrive SF	70 x 282mm (h x d)	N/A	N/A	900 - 1600mm	N/A	N/A	4 x 40kg
Revolving Doors	TSA 325 NT	1800 - 3600mm (dia)	N/A	N/A	895 - 2460mm	N/A	N/A	N/A

Above data subject to consultation

Support products

Safety systems and activation devices



Activation

Any automatic door system is incomplete without an activation device or safety features.

GEZE have a range of activation systems including infrared sensors, microwave sensors, radar sensors, radio-controlled transmitters, access control systems and push pads that are suitable for use in different applications.

We use our expertise to select the most appropriate device for each situation taking into account several considerations, for example, the positioning of the automatic operator in the building and whether it is exposed to the elements.

We will work with you to understand the type of usage expected through the entrance as cross traffic and the direction of traffic will all affect the choice of activation.

Another consideration is flooring. Floor finishes and reflective floors all influence the type of activation device selected.

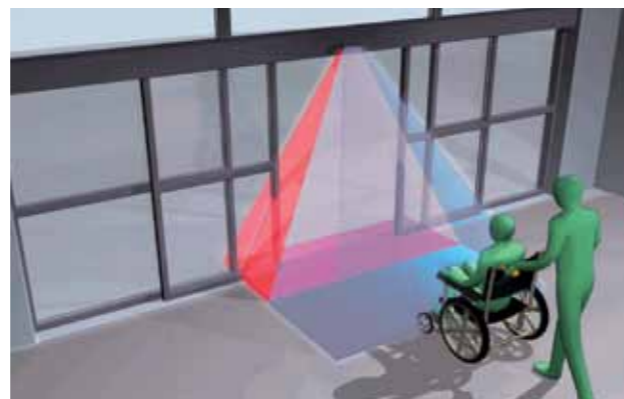

Clearwave

The Clearwave non-touch microwave technology door activation switch has been designed for installations where hygiene is of paramount importance such as hospitals, white rooms, food processing and chemical industry applications.

Providing hygienic door activation Clearwave has a sleek design, an adjustable touchless detection range from 5-40cm, is water resistant, easy to install and comes with three faceplate stickers to suit a variety of installation environments.

Safety

Whilst there is scope for customer preference on the choice of activation device, when it comes to safety there are standards that must be met.

Pedestrian safety is paramount and we have a range of devices to ensure you meet those operational standards and the expertise to guide you through your responsibilities.

Bollard solutions

We have developed a range of bollards to meet the highest demands of functionality in a choice of styles and materials. They are designed to work alongside any of the GEZE push pad switches or Clearwave switch.

Guide or barrier rails

Guide rails are an important part of automatic door installations. They are essential where traffic can approach from oblique angles and the door may present a hazard that cannot be avoided. Guide rails assist with safeguarding against traffic entering the path of a sliding or swing door whilst opening. In addition they ensure that pedestrian traffic is routed in the most appropriate direction towards the door opening.

Anti-finger trap systems

GEZE provide the widest range of anti-finger trap systems for single action doors. Safety and injury prevention is paramount. In order to assist with compliance to EN 16005 and the Workplace Safety Act 1992, the systems have been designed to provide solutions for virtually any door and frame type.

QuickCare

A wireless telemetry device using GSM and GPRS technology to enable remote monitoring and control of the door system.

Allowing the GEZE UK service network to provide an immediate response should operational issues occur. Critical activation & safety sensors are just a few devices that can be connected to the system, with signals recorded for monitoring purposes.

Most issues are generated by the various switching devices connected to the door operator. GEZE QuickCare allows trained service technicians to dial-in remotely to the door system and diagnose the error; repair or make safe in advance of a site call. Through GEZE QuickCare, we can know about an issue with an automatic door before the customer giving a double benefit of both response and reaction time and reducing engineer visits and carbon footprint.

Key Benefits

- Real time remote access and control
- Device monitoring ensuring continued compliance with BS 7036 / EN 16005
- Remote diagnostics pinpointing errors
- Client access to internet portal
- First level footfall reporting
- Automated alarm notification via email or text
- Standard reports for environmental impact
- Open times affecting heat loss, air con and refrigeration
- Operator & Sensor usage and state
- Usage of any Panic Devices
- History of Door settings (Night modes, Summer modes etc)

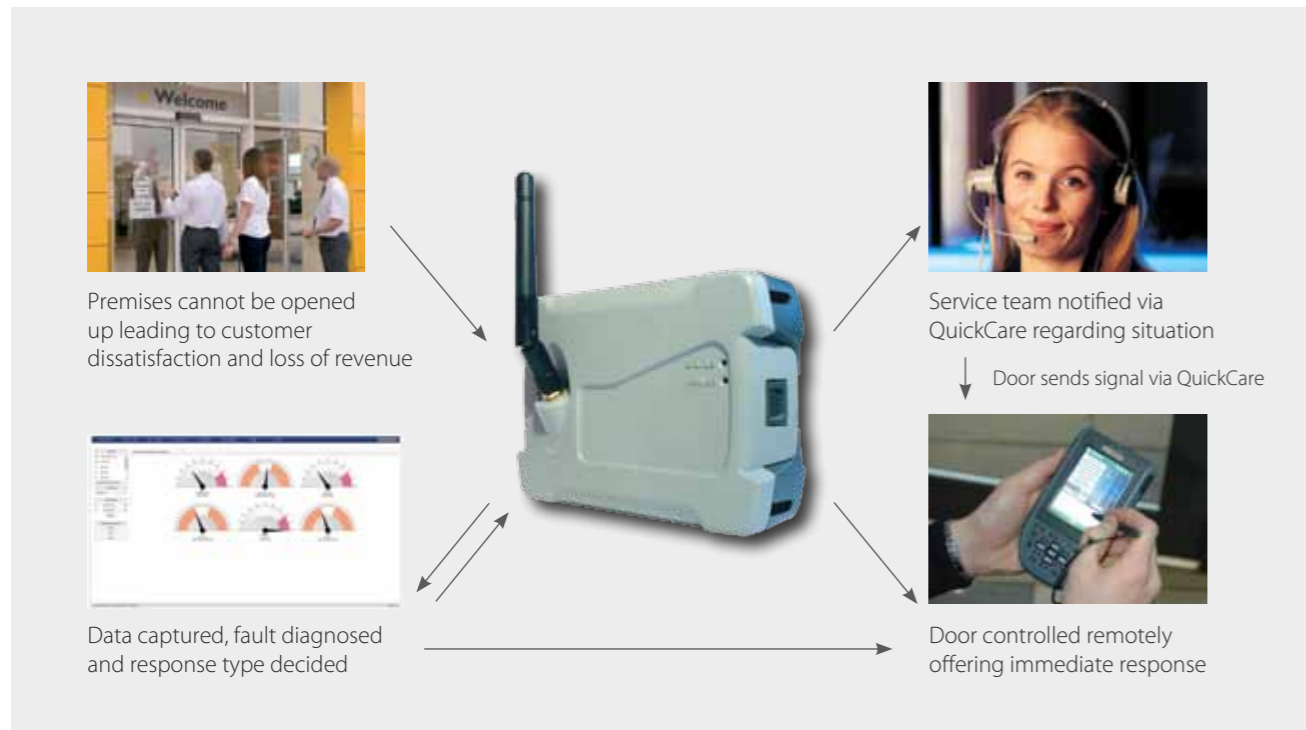

Repair and maintenance

GEZE UK's commitment to customer service doesn't stop at supplying automatic doors. We also provide a full range of repair and maintenance services.

So whether it is a fast efficient service to manage emergency door repairs that is needed or a cost-effective planned preventative maintenance contract to maintain the efficient working of entrance doors, we can help.

We offer a 24 hour, 7 day a week service to all makes of automatic and manual doors throughout the UK.

Our team of trained service engineers have all passed the Automatic Door Suppliers Association (ADSA) examination and are fully up to date with the requirements of EN 16005. All service engineers have vehicles stocked with the most popular components in the market to ensure that calls are completed, wherever possible, on the first visit to site.

GEZE UK operates from strategically located regional offices providing a local team of staff to respond fast to enquiries for both quotations and technical advice and deliver an emergency response when required. The local branch network is supported by our manufacturing base in Lichfield.

The company maintains a service management system recording every quotation and customer order. This enables both technical

and financial data to be called up quickly for transmission to both customer and service engineer when needed.

Since the introduction of EN 16005, all automatic doors must have a logbook to keep a detailed record of any servicing and maintenance work that has been undertaken. GEZE UK has developed '**logbooqr**', a new online logbook for automatic doors which can be accessed via a QR code using a smartphone or tablet. logbooqr allows this information to be recorded on a secure website which is accessed via a QR code printed on the asset tag. Engineers can record the work that has been done, and end users can check the log and see when the next service is due. In the event of an accident or random spot check, Health and Safety Inspectors can easily access this information to confirm that servicing and maintenance schedules are up to date.

GEZE have invested in the latest mobile technology and our Mobile Service Solution (MSS) has been developed to provide a software system that fully interfaces with our SAP™ operating system. It is tailored to our needs and those of our customers exactly and provides faster updates, immediate technical information, improved stock control and better customer service.

GEZE has built its reputation on producing quality products. The company offers quality performance in its relationships with customers, communicating at every stage of service from receipt of order, planning a service engineer's visit to reporting further work.



Your issues are our issues

Sustainability

Conservation and preservation of the natural environment is part of our social responsibility. From product development and production to sales we work according to the latest environmental standards.

We have committed to implementing, managing and maintaining an environmental management system that is compliant to the nationally and internationally recognised Environmental Standard BS EN ISO 14001:2004. This includes minimising all forms of waste, preventing pollution, reducing the use of natural resources and complying with all environmental requirements and legislation including those of our customers.

We can advise on creating environmentally friendly lobbies or positioning entrances so climate has minimal effect. We support campaigns such as Close the Door which encourages retailers to close their doors to save energy and improve air quality inside.

Safety

Whilst there has been a significant reduction in the number and rates of injury at work over the last 20 years, construction remains a high risk industry. Safety is a top priority for GEZE; we are committed to ensuring that industry safety standards continue to improve and safe working practices are followed.

We are members of several industry schemes focused on health and safety such as SafeContractor, Chas and ContractorPlus. GEZE project managers and engineers are ADSA qualified and trained to EN 16005 standards. We even undertake training developed by our customers to ensure a safe working environment on their premises.

We offer CPD seminars on EN 16005, Safeguarding Pedestrians at Power Assisted Doors and support campaigns such as Fire Door Safety Week.

Quality

When it comes to quality you can be sure of GEZE. Extensively tested at the company's technology centre in Germany, products are then tested externally and hold quality assessments such as Certifire, CE marking and Declaration of Performance.

Many GEZE products are recognised for their quality, design and functionality such as the Powerturn which won Best Product of the Year 2016 by the Plus X Awards.

GEZE are also members of organisations such as Constructionline, Achilles and Altius who are dedicated to assessing suppliers and ensuring their performance in the supply chain. Our professionalism is further demonstrated through our membership of well-respected industry organisations such as ADSA, RIBA, and FDIS.

Project delivery

Whether a large multi-storied, multi-roomed building or a simple standalone one, getting a project delivered on-time is a complex task requiring everyone to play their part.

GEZE's project managers are the first point of contact managing the project, liaising with internal teams and ensuring you are kept up to date all along the way.

When quoting for a project we quote to the standard EN 16005, so all safety and activation requirements are included.

GEZE invests in people, processes and machinery to enable us to offer flexibility, so when your project changes we can too.

Value

From state-of-the-art new buildings to the refurbishment of historical listed buildings GEZE has a range of products to meet the needs of any project. From a simple automatic swing door operator for internal use to the most complex of entrance systems involving several operators we work with your design team and can advise on the most appropriate operator.

But technical support is not limited to product information and as part of our service we offer guidance on legislation and regulations.

GEZE's technical and design teams have worked on all types of projects and have extensive experience to make sure you get the most suitable solution for the project, and the budget.

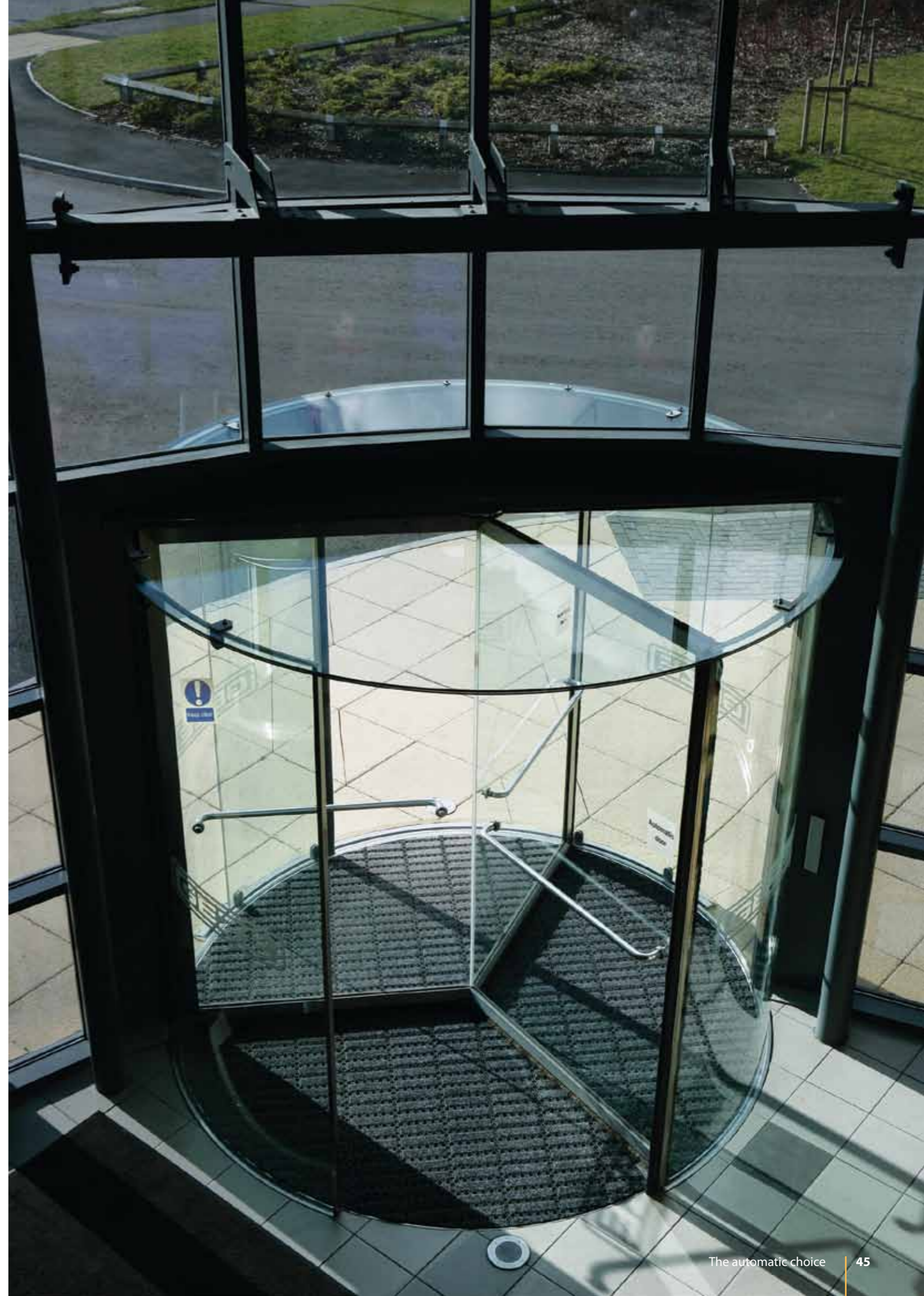

Accreditations

High standards of product quality, professionalism and health and safety are paramount in the construction industry. GEZE UK is a member of the following organisations that define and promote these standards.



ADSA

ADSA (Automatic Door Suppliers Association) ensures that its member companies offer superior levels of safety in the supply,

installation and maintenance of automatic doors and promotes the highest standards to help specifiers and potential customers obtain the best solution to their needs.



ISO 9001 and ISO 14001

GEZE UK holds the ISO 9001:2008 Quality Management System certificate and ISO 14001 Environmental Management certificate. We are committed to maintaining high standards,

regulatory compliance and continual improvement throughout our operations and working practices to ensure customer satisfaction.



ALTIUS

Altius are an independent company providing an efficient, effective service of

assessing suppliers and contractors ensuring that clients' specific requirements are met. GEZE UK has been awarded Elite Vendor status which is the highest accolade a company can achieve through the Altius assessment process and GEZE UK is only one of sixty Altius clients that have received this level of accreditation.



RIBA

GEZE UK is a member of the RIBA CPD Providers Network that offers architects and other construction professionals RIBA-assessed, high-quality CPD material.

We offer 4 RIBA approved seminars; EN 16005 Safeguarding Pedestrians from Accidents at Power Operated Doorsets, Glass Door Assemblies - Selection and Specification, Removing Barriers to Access, and Designing Effective Natural Heat and Smoke Ventilation.



SAFEcontractor

SAFEcontractor is an accreditation scheme that assesses the health and safety competency of contractors and service providers.

Clients have a legal obligation to ensure that external contractors and service providers working on their premises operate in a safe way. There is therefore a need to assess contractors' health and safety arrangements and increasingly this is being carried out through SAFEcontractor.



Constructionline

Constructionline is the UK's largest certified pre-qualification database for contractors and consultants. It aims to

improve efficiencies for buyers and suppliers in the construction industry, specifically by reducing the duplication of work and administration relating to the process of pre-qualifying suppliers for construction contracts.



CHAS

CHAS, the Contractors Health and Safety Assessment Scheme are dedicated to completing health and safety pre-

qualification assessments to a nationally recognised and accepted threshold standard. CHAS is a founder member of Safety Schemes in Procurement - Competence Forum or SSIP.



ContractorPlus

ContractorPlus is a web-based pre-qualification system of contractors who have been vigorously vetted to ensure their health and safety standards are of the highest quality.



Guild of Architectural Ironmongers

GEZE UK is a member of The Guild of Architectural Ironmongers, founded

in 1961 to promote standards in integrity and excellence in the business of Architectural Ironmongery. The Guild is Britain's only trade body solely dedicated to promoting the interests of the whole architectural ironmongery business - architectural ironmongers themselves, and the manufacturers and wholesalers of architectural ironmongery products.



BWF

BWF, the British Woodworking Federation is a business support organisation whose members have signed up to a rigorous set of standards of workmanship, company stewardship and environmental disciplines.



Achilles

Achilles is a rigorous accreditation process that quantifies, evaluates and monitors suppliers on behalf of buyers.



FDIS

The Fire Door Inspection Scheme, FDIS, provides education for anyone working with fire doors and escape doors. Under the

Fire Safety Order building owners need 'competent persons' to help them comply with fire door regulations. The FDIS education programme provides the path to becoming that competent person.



DHF

The DHF Door Hardware Federation is the only unified body representing the interests of industrial and garage doors, metal and timber doorsets, powered gates and the building

hardware sectors. Their main aim is to raise standards in these industries and reassure customers that they are using products and services of the highest quality that conform with the latest legislation and technical specification.



CAB

The Council for Aluminium in Building, CAB, aims to promote the use of aluminium in building through education, technical excellence and

encouraging the development of an increasingly professional and trained workforce in the sector.

The information provided in this brochure is for guidance only. For specific requirements please contact a GEZE UK representative.

